

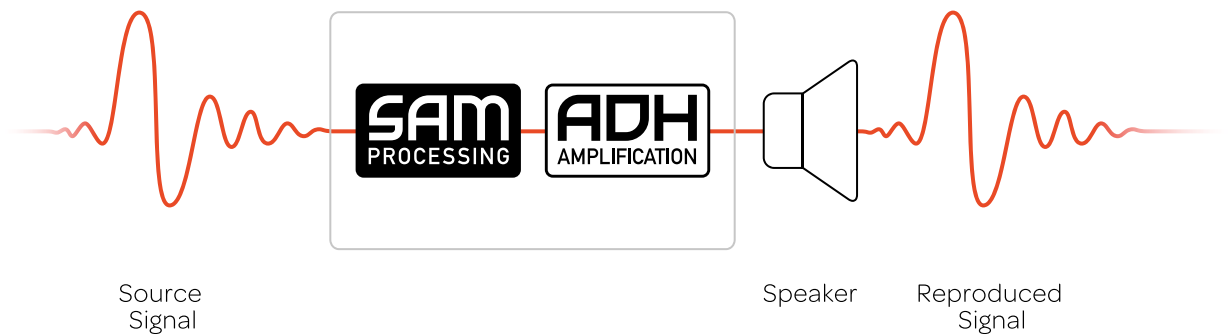

DEVIALET

ADH and SAM

white paper





DEVIALET'S ADH (ANALOG/DIGITAL HYBRID) AMPLIFICATION TECHNOLOGY

What is ADH?

ADH is the beating heart of any Devialet unit. It is what makes its amplification technology so unique and peerless. ADH is the very reason why Devialet exists, and it represents a major technical revolution such as there has not been in the audio industry for the last 40 years.

The idea beyond ADH is to combine the two opposed technologies of amplification - Analog and Digital, aiming to obtain *the best of both worlds*: the linearity and musicality of the most acclaimed analog amplifiers (class A) with the power, efficiency and compactness of «digital» amplifiers (class D).

Although simple to explain, this hybridization – first patented in 2004 - rapidly proved to be extremely difficult to realize, since it basically means connecting two amplifiers in parallel. In the end, 3 years of extensive research were needed to obtain a high power prototype with the best performance on the market.

How does ADH work?

ADH operates through the following enslavement principle (see figure 1):

| *A genuine class A amplifier directly connected to the speaker drives the output voltage: as the master, it sets the sound of the whole ADH core. That's why what we hear is an analog amplifier.*

| *Several class D amplifiers are added in parallel to provide the speaker with the current it requires to sustain the output voltage. They act as slaves to the master class A amplifier, minimizing its workload.*

An illustration of this principle is the power steering of a car: the driver is setting the car direction, assisted by a powerful engine to help turn the wheels, making the driver's job effortless and hence more precise.

A specific class A amplifier is required to fit in the ADH core: although it is most of the time highly assisted by the class D amplifiers in providing current to set the ideal voltage to the speaker, it must also be able to output a high current over a short period of time, and absorb the ripple current of the digital amplifiers.

This is achieved by a very innovative non-linear polarization scheme which allows a virtually infinite current while staying in class A, combined with a low power consumption. The intrinsic linearity and output impedance of this patented ultra-linear class A compare with the best units on the market.

Devialet Exclusive Audio Core featuring ADH technology diagram

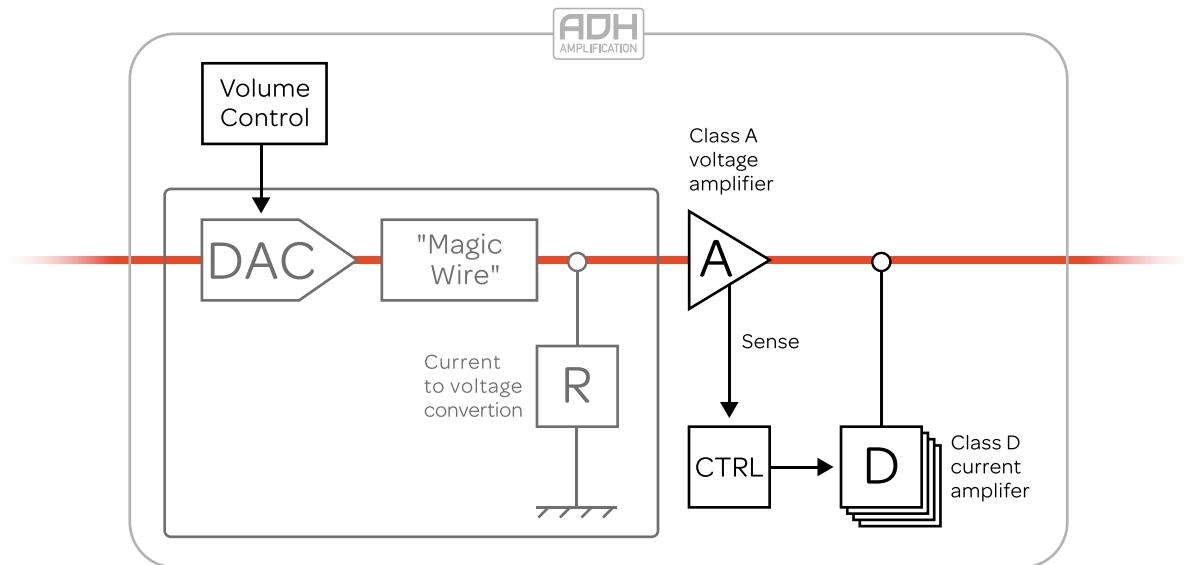

What are the benefits of ADH?

Thanks to the assistance of the class D amplifiers, the Class A is freed from the task of delivering much power and is made even more linear. As unexpected as it sounds, the class A is improved by the presence of the class D amplifiers in the ADH architecture!

Another benefit is that the output impedance of the ADH core is equal to the class A impedance divided by the current ratio of about 1:1000 between the class A and the class D amplifiers. That's how an output impedance of about $1\text{m}\Omega$ is achieved over the whole bandwidth, which is so important to maintain high performance while driving actual speakers presenting a complex load...

ADH technology truly fulfills Devialet's promise of a 'Pure Analog Sound with Smart Digital Power'. It offers the musical qualities of an outstanding class A amplifier, without its usual constraints of weight, volume and heat generation. The class D amplifiers provide substantial power to the class A without any compromise on the sound quality; on the contrary the class A amplifier performs even better when assisted by the class Ds.

A comprehensive demonstration highlighting the analog amplifier of the ADH core consists of removing the class D amplification daughter board: the Devialet still delivers very transparent and natural sound, but rapidly enters thermal protection when pushing the volume, as the class A has not been designed to deliver power over a great period of time.

DEVIALET'S "MAGIC WIRE" DAC

Just ahead of the ADH amplification stage, another major technological advance from Devialet is used: the "Magic Wire" DAC. The aim of the patented "Magic Wire" typology is to implement the DAC (Digital to Analog Converter) at the core of the class A amplifier, in order to reduce the parasitic, music-impeding phenomena - such as noise and distortion - to an absolute minimum.

In practice, the output current of the highest performance DAC on the market (Texas Instrument PCM1792) is directly converted into high-voltage without any processing in between: no operational amplifier, no current mirror. Instead, the very elaborate leak-less path of the "Magic Wire" carries the original current of the DAC to an ultra-high linearity resistor (16.7k Ω , 0.01% precision), which operates the current/high-voltage conversion before entering into the class A (see figure 1).

The magic comes from the fact that the guiding elements within the "Magic Wire" do not process the music, whilst providing high-voltage output. Besides, these guiding elements work at a stable power rate, hence constant temperature, which reduces thermal distortion to a non-measurable quantity. In a simplified view, the «Magic Wire» can be considered as the dream of every audiophile: *a straight wire with gain*.

This exclusive implementation transcends the PCM1792 to a level of performance never measured before, and forms the shortest analog signal path in the history of high-end audio: less than 5cm/2in between the resistor where the music voltage signal is born and the speaker binding posts. This optimized architecture is responsible for Devialet's sound transparency, immediately recognizable.

Devialet audio core measured performance table

PARAMETERS	«HIGH END»	DEVIALET	RATIO	CONDITION
SNR	100 dB	130dB 133dB in dual mono	1:32 1:45	A-weighted
THD	80 dB / 0.01%	100dB / 0.001% 112dB / 0.00025% in dual mono	1:10 1:40	Full power
IMD	70 dB / 0.03%	100dB / 0.001% 112dB / 0.00025% in dual mono	1:30	SMTPE
Zout Damping factor	0.1 Ω 80	1 m Ω 8000	1:100	Full bandwidth
Bandwidth	30Hz-10kHz 5Hz-60kHz	DC-30kHz DC-95kHz		-0.1 dB -3 dB
Phase	20°	0.4° 0.2° in dual mono	1:50 1:200	20 kHz
	35°	1.8° 0.9° in dual mono	1:20 1:80	40 kHz
Thermal Distortion		Not measurable		

DEVIALET'S SWITCHED-MODE POWER SUPPLY

The switched-mode power supply of the Devialet with Power Factor Correction presents the tremendous ability to deliver 3000W peak power, providing an absolute reactivity in transients as well as a total control of low frequencies. This substantial power capacity allows the ADH core to deliver such breathtaking depth and dynamics in sound.

Unlike so-called «linear» power supplies and traditional switched supplies, this supply draws power from the mains following a very clean sinusoidal waveform, ensuring a very low noise sent to the mains and to the internal blocks. Its Power Factor Correction (PFC) and DC/DC conversion are realized through a patented single-stage energy process, preventing power loss and offering an extreme overall efficiency of 85%.

MEASURED PERFORMANCE: PARAMETERS AND FIGURES

Every element of the Devialet exclusive audio core (ADH, "Magic Wire" DAC, switched-mode power supply) has been designed with one specific goal in mind: minimizing the effects of phenomena altering the musical signal, in order to obtain the most transparent and faithful reproduction of music.

Here is a key list of parameters against which the Devialet was evaluated throughout its conception:

- | *Signal/Noise Ratio (SNR): reflects the noise floor level under which music becomes masked, ruining the original ambiance and emotion during pianissimo moments*
- | *Total/Harmonic Distortion (THD): reflects the amount of spurious harmonics added to a single tone, hence timbers fidelity, since instrument sound signature is made of the ratio between these harmonics*
- | *Intermodulation Distortion (IMD): reflects the amount of spurious combinations of several tones: beyond THD, a very low IMD is mandatory to render the sound of a large orchestra without adding blur and to provide the original spatial definition without mixing the multiple paths of sound together*
- | *Frequency response, in both amplitude (bandwidth) and phase, defines the sound scene breadth and integrity, as well as the accuracy of high pitch timbres*
- | *Output impedance (Zout): defines the stiffness with which the amplifier sets the output voltage against the speaker's non-linearities and resonances; without an extremely low figure of this parameter, all the above discussed qualities measurable on ideal loads are lost in real life conditions*
- | *Thermal distortion: since the characteristics of any electronic device depend on its temperature, a non-constant operating temperature leads to a non-constant sound reproduction. Short-term thermal distortion alters the groove and the phrasing integrity of the system, and a longer term effect reduces the immediacy of forte/piano subito and the emotion deriving from this contrast*

The Devialet has been designed with strictly no compromise on any of those parameters, pushing the studies via permanent mutual challenge within the team.



DEVIALET'S SAM (SPEAKER ACTIVE MATCHING)

What is SAM?

After ADH amplification technology, SAM is Devialet's second technical revolution.

SAM is the intelligence that allows a Devialet to adapt its behaviour to the very loudspeakers it is connected to.

It provides for the first time a fully objective answer to the question : which electronics should I use, to get the best from my loudspeakers ?

Devialet's SAM consists in a processing of the audio signal in the digital domain, computed in the DSP that takes place in a Devialet ahead of the DAC and power amplifier section. By taking into account the characteristics of the loudspeaker connected to the Devialet, it allows to drive in a very precise and controlled way the speaker driver diaphragm's movement , so as to obtain an exact alignment between a recorded music signal, and the pressure wave that reaches the listener's ear during a listening session.

How does SAM work?

Where ADH is the engine imposing the signal at the speaker's inputs, SAM is the intelligence that allows this engine to impose a given signal at the speaker's output , by having in-depth understanding of the loudspeaker's behaviour.

SAM acts on the loudspeaker's motion by means of a novel processing of the audio signal that is performed in the time-domain, using a unique proprietary mathematical approach to reach an acoustic performance that is close to perfection. It optimizes in real time the loudspeaker's acoustic response, at every moment, on any signal.

A mathematical model of the complete loudspeaker, accounting for the electrical, mechanical and acoustical behavior (crossover filter, speaker driver, acoustic load) is running in real time on a DSP, that is like the brain of the Devialet. It computes for every sample the exact voltage that has to be applied to the loudspeaker input by the power amplifier, so that the acoustic pressure is a one-to-one image of the audio signal.

A Devialet can therefore free the loudspeaker from a number of the limitations dictated physics. A passive loudspeaker forms with the Devialet an intelligent active set-up.

Other techniques aiming at loudspeaker optimization are commonly simply equalization performed in the frequency domain. They typically involve IIR or FIR filters and cannot reach the same performance, being affected by such phenomena as extra phase rotation or time delay, and in general sub-optimal performance on transients.

SAM block diagram

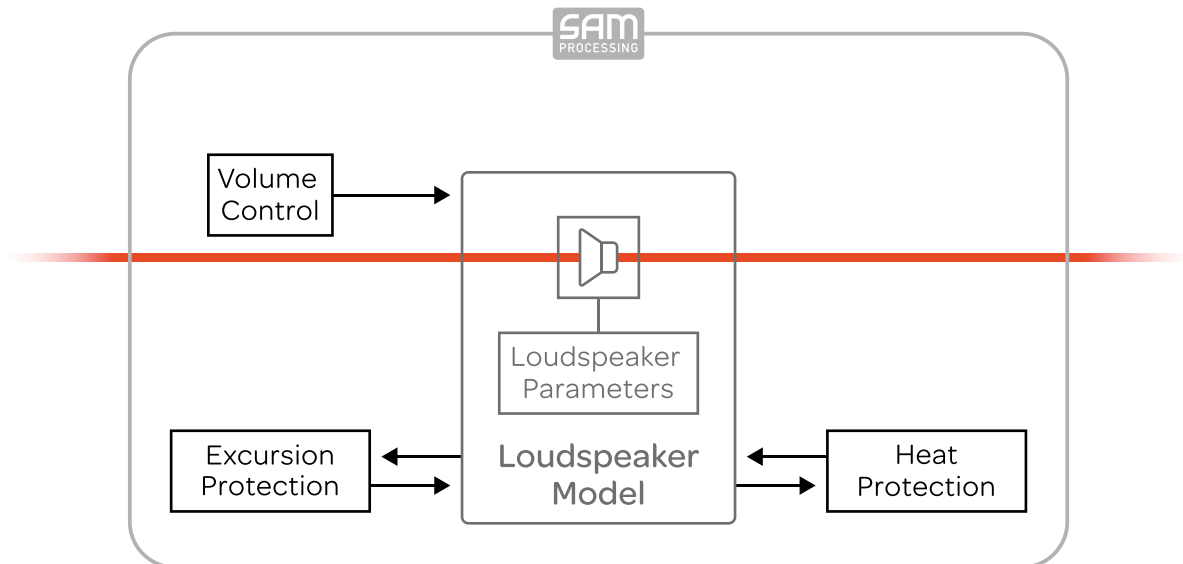

What are the benefits of SAM?

Devialet Speaker Active Matching is a truly high-end audio signal processing. SAM has a qualitative effect, rather than a quantitative one: one should not expect the speakers to sound very different, but to sound better. Depending on the music track, the benefit will be obvious or may be subtle, but after having tried listening with SAM one does not want to go back.

In its current implementation, SAM is effective on lower frequencies, up to 150Hz; yet its effects can be heard throughout the audio range.

By its principle, SAM ensures that the acoustic response is at every instant an extremely faithful image of the recorded signal; this is true on transient signals (notes attacks, drums, ...) as well as on continuous signals (notes sustain, organ...).

In particular, SAM prevents any delay between bass and the rest of the spectrum, avoiding the effect of the phase rotation at the vicinity of the natural low-frequency cut-off of the loudspeaker.

Although SAM is in nature and effect radically different from a bass boost, it actually increases the low-frequency extension of the loudspeaker. Since SAM technology ensures that the music waveform is reproduced exactly as it should in the time domain, even frequencies below the natural loudspeaker cut-off are faithfully represented.

This is of course done within the physical boundaries of what the loudspeaker can do: maximum excursion of the speaker driver, and maximum continuous power handling. These physical limitations are accounted for in SAM processing. As a result, SAM is also an effective protection of the loudspeaker, helping to prevent any damage to occur due to listening at high levels.

Effect of SAM on loudspeakers' response

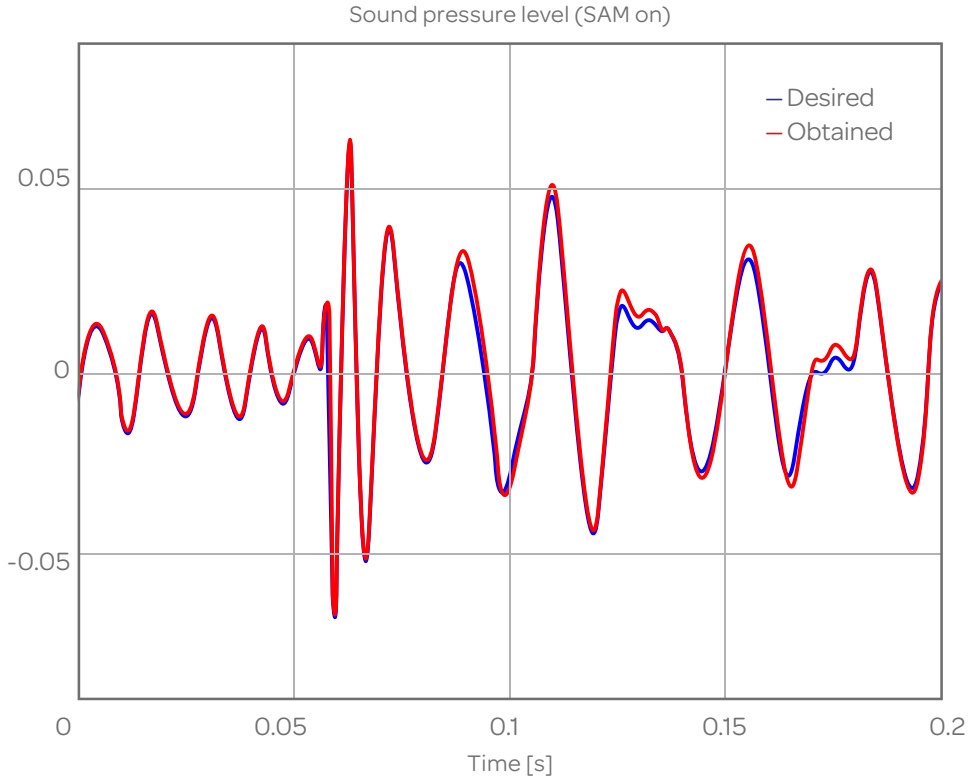
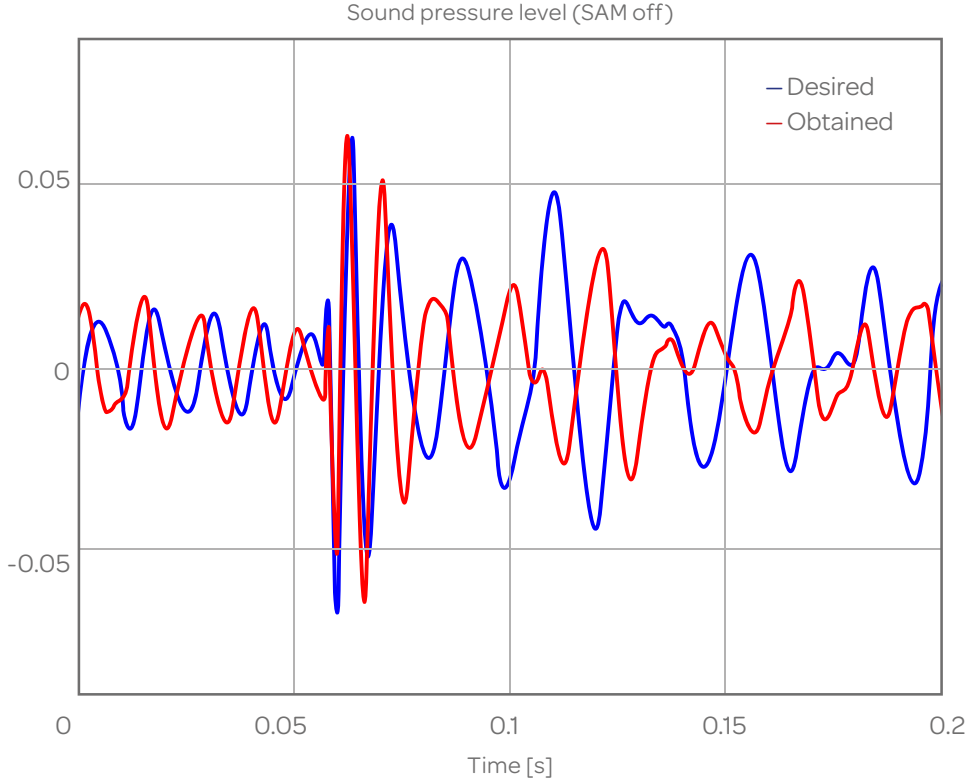

SAM is implemented as a time-domain signal processing using unique patented mathematical techniques, featuring:

- | *zero latency*
- | *no pre-echo*
- | *no feedback*

Here are some of the key subjective, audible, benefits of SAM mentioned by listeners:

- | *higher impact, particularly on transients*
- | *better sense of pace and music tempo*
- | *better sound image*
- | *higher level of detail*

Can I use SAM with my speakers?

SAM is by principle compatible with all loudspeakers. Just pick your loudspeakers on the list of already supported models in the Devialet configurator. And if your speakers are not yet on the list, go to voteforsam.devialet.com to put them on the high priority list.

SAM does not use any feedback, and does not necessitate the use of an external sensor (microphone, accelerometer...), therefore making it potentially compliant with any passive loudspeaker on the market.

It also does not require calibration for each and every unit of a loudspeaker model : simply connect your Devialet configured to match your loudspeaker model, and it will work.

SAM keeps all the qualities and the own character of the sound of the loudspeaker, yet reveals the loudspeaker's full potential, extracting the very best performance ever heard from a given model.

What makes it possible?

The result of 3 years of intensive research in electroacoustics and signal processing, protected by two patents for a global protection, Devialet's SAM is available only on a Devialet. Sam works on any Devialet, the hardware upgrade option offered to D-Premier owners making their Devialet SAM-compatible.

Thanks to ADH amplification technology, a Devialet has an extremely precise control of the loudspeaker cone motion. This precision and control opens new possibilities in the field of loudspeaker behaviour optimization.

Each Devialet uses 10 micro-processors or micro-controllers, including 3 high performance SHARC DSPs clocked at 400MHz. This significant computation power is used in a unique and evolutive way, thanks to a SD card and the online Devialet configurator, which allows to reprogram your Devialet entirely with a simple file download.

Devialet engineers have developed a characterization protocol including electrical, mechanical (laser interferometry) and acoustical laboratory measurements to be able to model the exact behaviour of any loudspeaker. They have industrialized the process to be able to develop SAM processing for any speaker, from initial measurements to final robustness testing. It all happens at Devialet headquarters in downtown Paris.

CONCLUSION

From the start of the Devialet project, SAM was part of the plan. A DSP was reserved to perform loudspeaker-related signal processing. After having focused on amplification, the second step of the Devialet project was to drive loudspeakers in a specific, dedicated way.

10 years after patenting ADH, Devialet introduces commercially their Speaker Active Matching, technology: whichever speakers you own, a Devialet will make them sound like no other system is capable of, making you want to rediscover your whole music collection.

ADH and SAM block complete diagram

